

LAZZARI

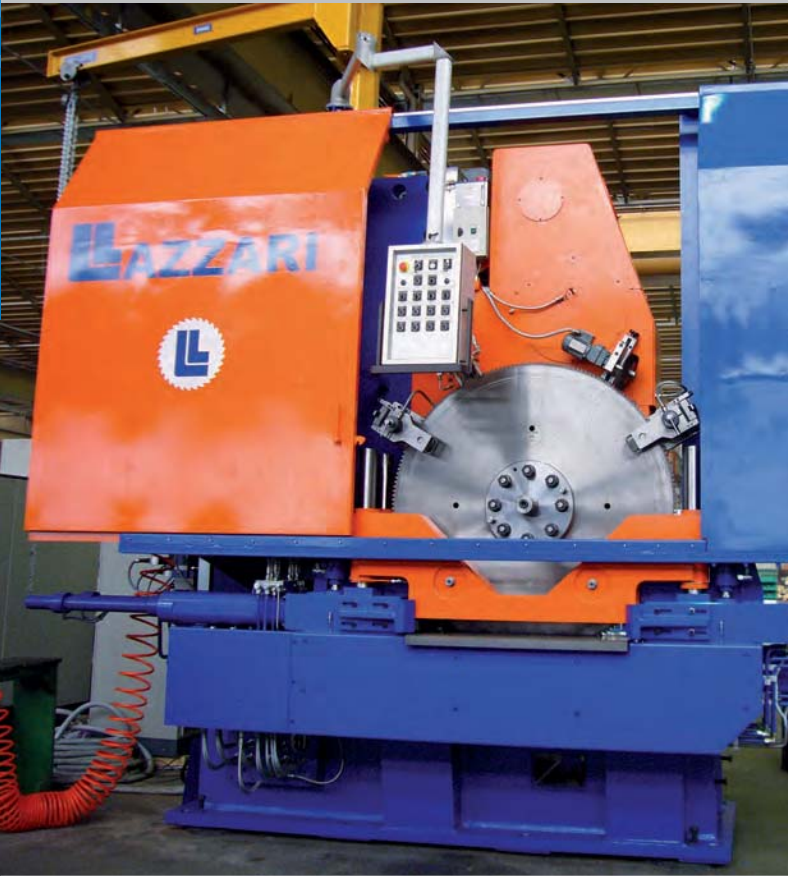

Officine meccaniche Impianti industriali S.p.A.

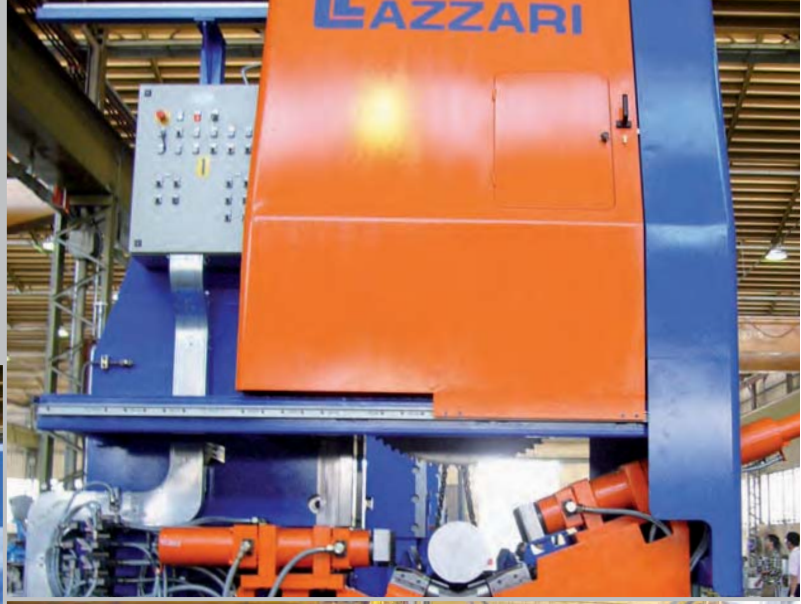

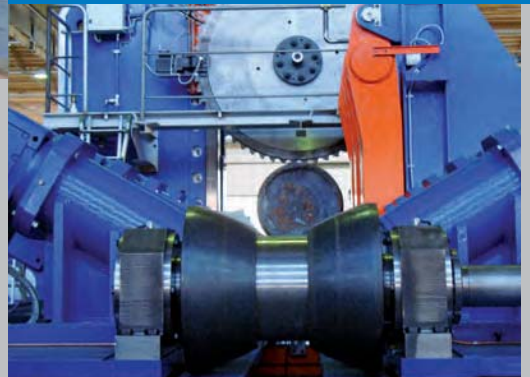
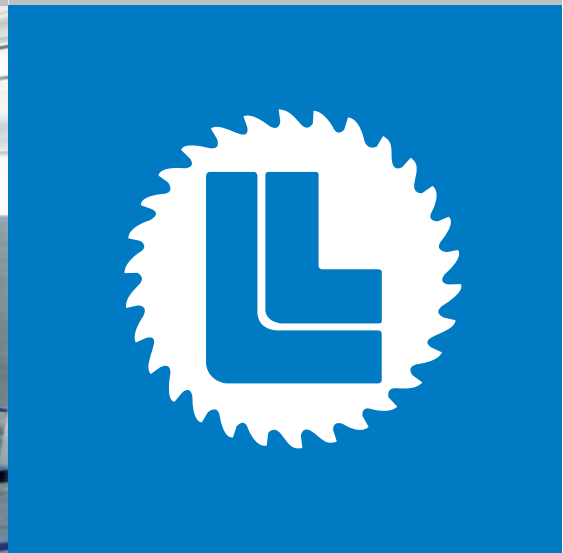
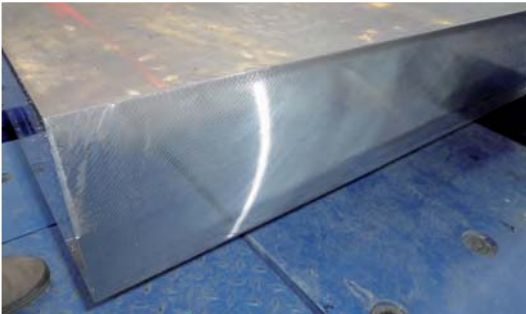

General technical description

- *Sawing machines are designed to cut steel material with different sections single or in layer*
- *Bedplate in strong welded steel, dimensioned to assure the maximum stability*
- *Saw blade head made up of a reduction gear box with box in welded steel and helicoidal gears; automatic and continuous backlash compensation; safety joint; AC motor with frequency regulator*
- *Saw blade feed system by vertical guides with continuous backlash compensation, ball screw, brushless motor and hydraulic counterweighing system*
- *Horizontal and/or vertical clamping system to clamp the material to be cut*
- *Kerf opening system*
- *System to dump saw blade vibrations*
- *Brush system to clean the teeth of the saw blade*
- *System to cool and lubricate the saw blade by air mist*
- *Chip conveyor system*
- *Saw blade changing system*
- *Hydraulic plant complete of hydraulic power unit, valve block and piping on board*
- *Centralized grease lubrication system*
- *Electric plant/automation made of a control desk, an electric cabinet complete of PLC to control the cutting cycle, diagnostic system with alarm to prevent failures*
- *Options:*
 - *Customized In-Feed and Out-Feed systems to handle the material*
 - *Customized systems for measure cutting*
 - *Control system on Personal Computer Windows*
 - *System to check the wearing status of the saw blade*
 - *Tele-maintenance service*

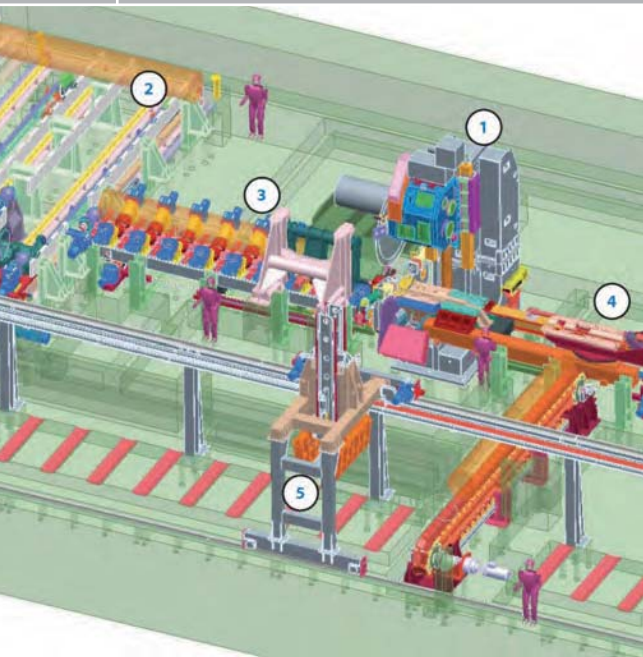



LAZZARI SAW FOR SINGLE CUT

Type Single cut	Saw blade Ø/mm	Material Dia. mm	Material X x X max mm
(*) S900	400 - 900	40 - 280	260 x 260
(*) S1100	600 - 1100	60 - 380	320 x 320
(*) S1400	900 - 1400	140 - 480	420 x 420
(*) S1700	1100 - 1700	250 - 550	520 x 520
(*) S1900	1400 - 1900	300 - 640	580 x 580
(*) S2200	1500 - 2230	400 - 830	680 x 680

(*)

B	Bars
T	Tubes
P	Profiles

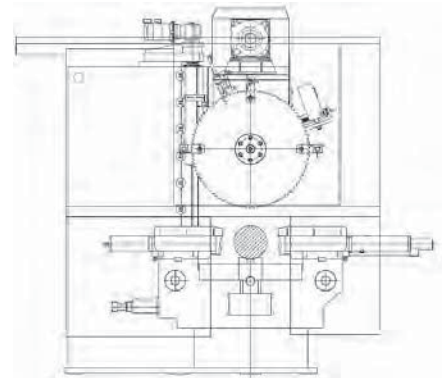

LAZZARI SAW FOR LAYER CUT

Type Layer cut	Saw blade Ø/mm	Layer Width / Height mm
(*) L900	400 - 900	550 / 15 - 180
(*) L1100	600 - 1100	700 / 15 - 240
(*) L1400	900 - 1400	900 / 25 - 300
(*) L1700	1100 - 1700	1100 / 40 - 360
(*) L1900	1400 - 1900	1300 / 80 - 420
(*) L2200	1500 - 2230	1500 / 160 - 500

(*)

B	Bars
T	Tubes
P	Profiles

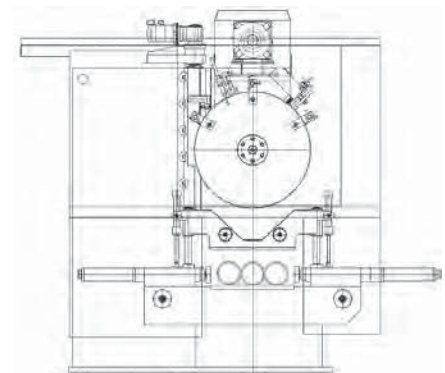

LAZZARI SAW FOR PLATES

Type Single plate	Saw blade Ø/mm	Plate Width / Height mm
HS1000	700-1000	2000 / 250
HS1400	900-1400	2500 / 400
HS1800	1300-1800	3000 / 600

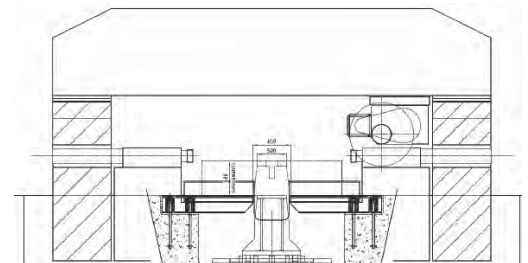

LAZZARI SAW FOR RAILS

Type Single rail	Saw blade Ø/mm	Rail Width / Height mm	
RS800	400 - 800	90-300 / 90-300	Only saw
RS800-D3	400 - 800	90-300 / 90-300	+ 3 holes drill
RS800-D6	400 - 800	90-300 / 90-300	+ 6 holes drill

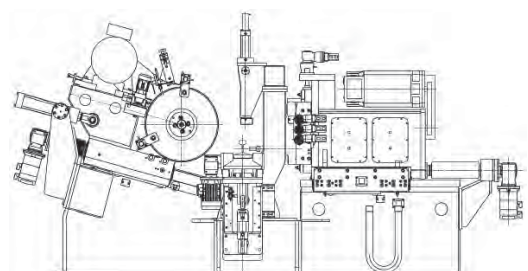



LAZZARI

LAZZARI - OFFICINE MECCANICHE
IMPIANTI INDUSTRIALI - S.p.A.

Via A. Volta, 3
24036 PONTE S.PIETRO (BG) - ITALY
Tel. +39 035 611316 Fax +39 035 612402
e-mail:lazzari@lazzarigroup.com

www.lazzarigroup.com

